

### Additional Terms & Conditions (ATC)

1. Bidder shall upload the signed and stamp copy of, Technical Specification at **Annexure-A**, as a token of their unequivocal acceptance.
2. **Declaration:** The bidder will submit “Bid Declaration Form” along with their bid. Bid Declaration Form is enclosed as **Annexure-I**.
3. **Earnest Money:**
  - a. The offer must be accompanied with an Earnest Money Deposit (EMD). EMD shall be deposited online (RTGS/NEFT/UPI) to SJVN Thermal (P) Ltd. Bank Account as per following details:

Beneficiary Name	<b>SJVN Thermal Private Limited</b>
Account No.	<b>046505003266</b>
IFSC Code	<b>ICIC0000465</b>
Bank & Branch	<b>ICICI BANK, BUXAR BRANCH, PP ROAD, SAHU COMPLEX, 802101</b>

**(Payment acknowledgment shall be uploaded on GeM portal)**

**Caution:** Please ensure that you need to mention the correct beneficiary account number and IFSC code as mentioned above while making payment via RTGS / NEFT. In the event of funds remitted to wrong beneficiary account number, SJVN Thermal Private Limited or its Bank or its service provider would not responsible for the same.

**Bidder can also submit their EMD/bid security in following modes:**

- i) Demand Draft/Bankers Cheque in favour of ‘SJVN Thermal Private Limited’, Payable at ‘Buxar’,
- ii) Bank Guarantee (BG) issued by any Nationalized / Scheduled Banks
- iii) FDR pledged in favour of ‘SJVN Thermal (P) Ltd.’

**(Other mode of payment shall not be accepted).**

**Note: While preparing the BG (enclosed as Annexure-V) in favour of SJVN Thermal Private Limited or extensions thereof as the case may be, bidder may ensure to mention above Bank details in order to BG verification through SFMS facility.**

- b. Bid security shall remain valid for a period of 45 days beyond the original bid validity period and beyond any extension will be subsequently requested if any. Any correction, alteration and addition in computer generated / other hand-written instrument subsequently needs to be attested by the appropriate authority of bank.
- c. EMD of the bidder shall be forfeited, if the bidder withdraws or amends its bids or impairs or derogates form the bid in any respect with in the period of validity of the bid. The EMD of the successful bidder shall be retained as contract security until such period the contractor furnishes the required security deposit / complete the scope of supply. If the contractor is failed to fulfill his obligations, the EMD, retained as contract security shall be forfeited. The Demand Draft/Bankers Cheque/BG/FDR in original should reach within **Seven days (07)** from the Bid opening date at the address given below:

**O/o Head (Contracts)  
Procurement and Contract Deptt.  
Main Office Building, SJVN Thermal Pvt. Ltd.,  
Buxar Thermal Power Project, Mohanpurwa,  
Akhouripur-Gola, Chausa, Buxar. 802114(Bihar).**

- d. **Exemption from EMD for MSEs/Startups/eligible bidders as per GeM GTC:** Startups recognized by the Department for Promotion of Industry and Internal Trade (DPIIT) and Micro and small enterprises (MSEs) who are registered with District Industries Centers (DICs) / Khadi & Village Industries Commission (KVIC) / Khadi & Village Industries Board (KVIB) / Coir Board / NSIC / Directorate of Handicrafts and Handloom or any other body specified by Ministry of Micro, Small & Medium Enterprises (MoMSME) are exempted from furnishing the bid security/Earnest Money Deposit (EMD).

If the MSE/NSIC/Startup India certificate does not contain the item(s)/work(s)/Services as listed in our NIQ/NIT and no Bid Security(EMD) is found submitted, then STPL may ask the bidder to submit the Bid Security(EMD) and the same should reach within stipulated timeline from the date of STPL's notification by GeM clarification, otherwise the bid shall be considered as non-responsive and price bid of such firms shall not be opened.

Further, the sellers/bidders shall be exempted from furnishing bid security as per GeM GTC.

**The scanned copy of the valid MSME / Startup India registration or any other documentary evidence against relevant category of exempted bidder shall be uploaded on GeM Portal.**

**Note-**

1. Benefits under PPP 2012 for MSEs are applicable only for **(a) Goods produced and (b) Services provided by MSEs. MSE benefits shall not be applicable to Trader/Dealer of Goods.**

**➔ Copy of PAN, Copy of GST Registration & Bank account details including cancelled cheque shall be provided by the bidder along with his bid for release of payments/refund of EMD. Bank charges if any, shall be borne by the bidder.**

#### **4. CORRUPT OR FRAUDULENT PRACTICES:**

*(enclosed as Annexure-II)*

- A. It is expected from the bidders / Contractor and/or any of its personnel, or its agents, or its Sub-contractors, manufacturer, sub-consultants, services providers, suppliers and/or their employees that they will observe the high standard of ethics during the bidding process and execution of such Contracts. For this purpose, the applicant shall sign the undertaking as per Annexure-I. In pursuance to this policy:

(a) for the purposes of this provision, the terms set forth below as follows:

(i) "Corrupt practice" means the offering, giving, receiving or soliciting of anything of value to influence the action of a public official in the procurement process or in contract execution

(j) (ii) "fraudulent practice" means a misrepresentation or omission of facts in order to influence a procurement process or the execution of a contract to be detriment of the

Employer, and includes collusive practice among Applicants (prior to or after bid submission) designed to establish bid prices at artificial non-competitive levels and to deprive the Employer of the benefits of free and open competition.

- B. A Bid shall be rejected by the Employer if it is determined at any stage that respective bidders / Contractor and/or any of its personnel, or its agents, or its Sub-contractors, manufacturer, sub-consultants, services providers, suppliers and/or their employees has engaged in corrupt or fraudulent or collusive practices in competing for the Contract in question.
- C. The Employer will declare a bidder / contractor ineligible or may terminate the contract, either indefinitely or for a stated period of time, to be awarded a Contract if it at any time determines that the bidders / Contractor and/or any of its personnel, or its agents, or its Sub-contractors, manufacturer, sub-consultants, services providers, suppliers and/or their employees has engaged in corrupt or fraudulent or collusive practices in competing for or in executing the Contract in question.

## 5. Clarification of Bidding Documents

A prospective Bidder requiring any clarification to the bidding documents may notify the Employer through GeM Portal <https://gem.gov.in> or through e-mail [pcdbtpp@sjvn.nic.in](mailto:pcdbtpp@sjvn.nic.in) or in writing by post at the address indicated in ATC. The Employer will respond to such requests through the portal <https://gem.gov.in>. Any clarification requiring an amendment to the Bid Documents shall be issued as Addenda/amendment. Further, mere request for clarification from the Bidders shall not be a ground for seeking extension in the deadline for submission of bids.

## 6. Restrictions on Procurement from a Bidder of a Country which shares a Land Border with India

*(enclosed as Annexure-III)*

Any bidder from a country which shares a land border with India will be eligible to bid in this tender only if the bidder is registered with the Competent Authority specified in Annexure-I of Ministry of Finance, Government of India order no F. No. 6/18/2019-PPD dated 23.07.2020 and various amendment/clarification issued in this regard. The bidder has to submit the undertaking regarding compliance of above-mentioned order. In case the undertaking given by the bidder whose tender has been accepted by the Employer is found false at the later stage, this would be a ground for immediate termination and further legal action shall be taken in accordance with law.

## 7. PPP MII order (Local content Certification)

*(enclosed as Annexure-IV)*

**Class-I local supplier:** ‘Class-I local supplier’ means a supplier or service provider, whose goods, services or works offered for procurement, has minimum **60% local content**, as defined in DPIIT order dated 16-09-2020.

- (i) In line with the DPIIT PPP-MII order dated 16.09.2020 and MOP orders dated 20.12.2018 & 28.07.2020 including its subsequent revisions / amendments, “Only Class-I Local Supplier” shall be eligible to bid in this tender and the bidder shall submit the Self-Certification in original as per as per Performa, certifying that the item offered meets the Local Content requirement for Class-I Local Supplier, on a letterhead of firm.

(ii) “Self-declarations/ auditor’s/ accountant’s certificates submitted by the manufacturer / supplier / Service provider may be verified randomly by the committee constituted as per MOP Order 28- 07-2020 and its subsequent revisions / amendments / order, if any. In case of false documents/misrepresentation of the facts requisite action against such manufacturer/ supplier will be taken based on the recommendation of the Committee”

**8. Prices:** Prices shall be on F.O.R. basis at SJVN Thermal Pvt. Ltd., Buxar Thermal Power Project, Mohanpurwa, Akhouripur, Gola, Chausa, Buxar, Bihar - 802114.

**9. Dispute resolution:** In case of any dispute arising out of above conditions, the matter will be initially referred to the sole arbitration by CEO, SJVN Thermal Pvt. Ltd., Buxar Thermal Power Project. However, if dispute still remains unresolved, then the dispute will be resolved as per Indian Arbitration Act 1996. For un-resolved disputes, the Court at Buxar shall have the jurisdiction to adjudicate upon the matter.

**10. Common IP Addresses:**

Bidders may please note that GeM is capturing and showing the IP addresses used by the Buyer and the Bidder(s) /Seller(s). The received bids having matching/common IP address with either Bidder(s)/Seller(s) or Buyer, shall be outrightly rejected & shall not be considered for further evaluation.

**11.** SJVN Thermal reserves the right to adjust arithmetical or other errors in this tender/ATC in the way which it considers suitable.

**12.** All submissions/ correspondence /clarification and any other information, with regard to the above shall be made at the following Address:

Designation: **Head (Procurement & Contracts)**

Office Address: SJVN Thermal (P) Ltd., Buxar Thermal Power Project, Main Office Building, Mohanpurwa, Akhouripur-Gola, Chausa, Buxar- 802114 (Bihar)

Phone No. 06183-295275, Email: pcdbtpp@sjvn.nic.in



**SJVN Thermal Pvt. Limited**  
(A wholly owned subsidiary of SJVN Ltd. A NavRatna & Scheduled 'A' CPSE under Govt. of India)

**Buxar Thermal Power Project (2X660MW)**

Chausa, Buxar - 802101 (Bihar)

(Our Shared Vision: 25000 MW by 2030 & 50000 MW by 2040)

**Boiler Maintenance Department**

---

## Technical Specification of Mechanical Seal

### **1) Mechanical seal for Mill lube oil pump:**

**Pump Type:** Triple Screw Pump

**Make:** M/S Allweiler India Pvt. Limited

**Model :** Triple Screw Pump ,T3SI- 70/40

**Media :** Lube oil VG-320 grade

**Shaft size=**45 mm

**Mechanical Seal type :** Single Elastomeric Bellow

**Mechanical seal material – STEEL, FACES :-** Carbon/SiC,

Seal ring –Carbon

Mating ring SiC

Secondary packing –Viton

Spring holder –SS 316

Spring –SS 316

### **2) Mechanical seal for SG DMCW Pump:**

**Pump Type:** Horizontal Centrifugal Split Case Pump

**Pump Make:** Flowmore Ltd

**Pump Model:** F5826-250x200

**Media:** DM Water

**Temp:** 50

**Shaft Size:** 98.43 mm/3.875 inch

**Mechanical Seal Type:** 82

**Mechanical seal material :**

Seal ring –Car in CF8M

Mating ring - SiC

Secondary packing –Viton

Grub Screw –SS 316

Lock PIN –SS 316

CLIP- Steel

ORing-FKM

Drive collar-CF8M

### **3) Mechanical seal for CTP Pump:**

**Pump Type:** Horizontal Centrifugal Pump

**Pump Model :**UNIGLDE(BBI)

**Pump Make :** Clyde Union Pumps Ltd

**Shaft Size:** 80mm

**Media:** Condensate Water

**Temp:** 120 Maximum

**Mechanical Seal Type -**209 DCS-080

#### **Mechanical seal material**

Rotary seal ring –Hard Carbon

Stationary seal ring –Silicon carbide

Secondary seal –EPDM

Spring-Hastelloy C4

Gland plate,seat ring,pin,shaft sleeve, -316TI

Assembly ring ,cylinder screw,plug-316

Assembly fixture -431

**BILL OF MATERIAL**

RECOMMENDED SPARE PARTS

SR NO	PART NO	DESCRIPTION	MATERIAL	QTY	SPARE
1	174	SEAL RING	CAR IN CF8M	1	#
2	220	MATING RING	SIC	1	#
3	301A	O-RING	FKM	1	#
4	301B	O-RING	FKM	1	#
5	321	O-RING	FKM	1	#
6	411	SPRING	SS 316	12	#
7	431	GRUB SCREW	SS 316	6	#
8	515	LOCK PIN	SS 316	4	#
9	570	DRIVE COLLAR	CF8M	1	#
10	594	CLIP	STEEL	3	#

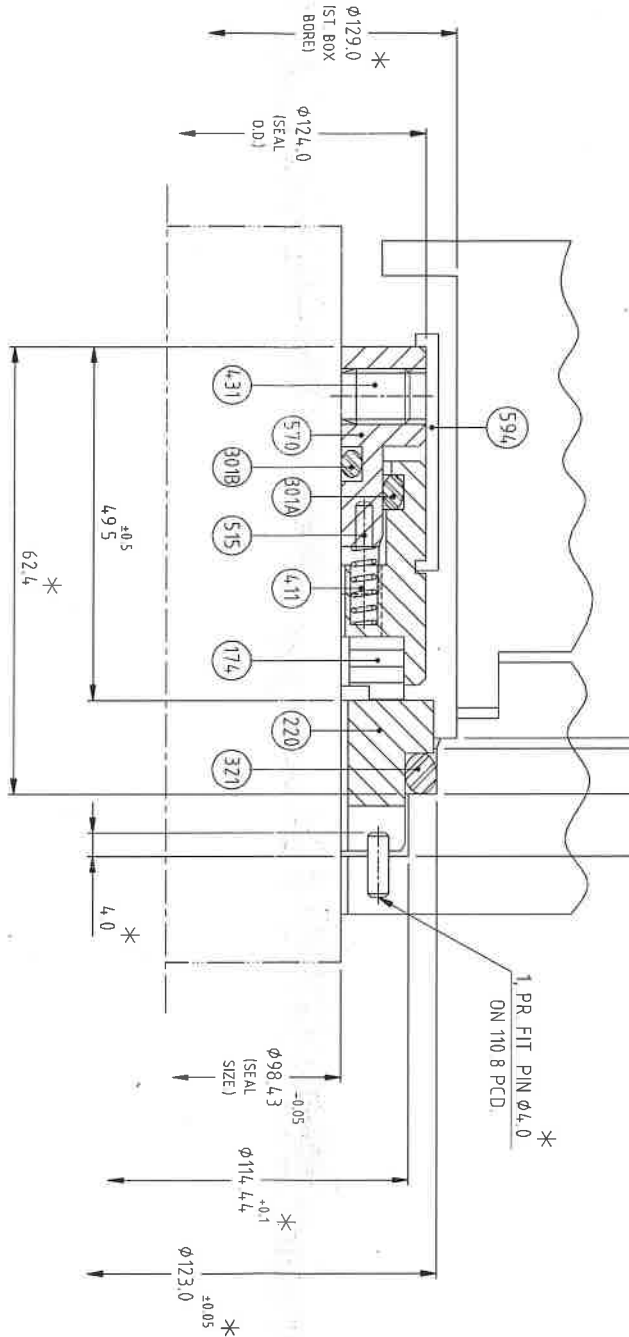

MWP-25 bar (MAX)  
 W O N O :- SALE 21 07 5163 20  
 CLIENT TO MAINTAIN DIMNS. MARKED THUS '\*'

**API PLAN DESCRIPTION**

PLAN	DESCRIPTION
API PLAN	API PLAN
FLUID TYPE:	WATER
FLUID:	50°C
FLUID PR:	
FLUID TEMP:	
FLUID RATE:	

**API PLAN DETAILS**

OPERATING PARAMETERS	CUSTOMER/EQUIPMENT DETAILS
SUC PR	BUYER:
DISC PR	FLOWMORE LTD.
BOX PR	USER:
TEMP	TEMP
50°C	
VELOCITY:	USER:
SP GR:	
1	
REF. DRG. NO.:	
A32 7110	

**REVISIONS** Page 112 of 164

REV	DETAILS	ZONE/APPD	ECN #	DOCUMENT #	DATE
1					

**INSTALLATION AND OPERATION INSTRUCTIONS**

- SEAL SHOULD BE OPERATED WITHIN PRESCRIBED PARAMETERS. IN ABSENCE OF ANY PARAMETER IN THIS DRAWING, USER SHALL CONSULT LEAK-PROOF ENGINEERING BEFORE USE.
- ALL SEAL PARTS ARE CRITICAL. OBSERVE CLEANLINESS AND EXTRA CARE WHILE HANDLING.
- REMOVE ALL SHARP EDGES ON SHAFT/SLEEVE BEFORE INSTALLATION.
- LUBRICATE SHAFT/SLEEVE AND WEDGE/O-RING TO ASSIST INSTALLATION. DO NOT USE OIL/GREASE ON EPDM/O-RING. DO NOT USE SILICON BASED GREASE ON SILICON O-RING. LUBRICATE THEM WITH WATER OR SOAP BASED SOLUTION. BLEED ALL LINES AND SEAL CHAMBER AND ENSURE THAT ALL CONNECTIONS ARE TIGHT.
- OPEN ALL FLUSHING/QUENCHING VALVES AND ENSURE FLUID FLOW ON MULTIPLE SEAL ARRANGEMENTS PRIOR TO EQUIPMENT START-UP.
- FOR DETAILED INSTALLATION, OPERATION AND DISPOSAL INSTRUCTIONS PLEASE READ THE APPROPRIATE LEAK-PROOF ENGINEERING SEAL OPERATING MANUAL.

**EQUIPMENT CONDITION**

SYMBOL	DESCRIPTION	VALUE
—	SHAFT/SLEEVE RUNOUT PER 1mm OF SHAFT DIAMETER	0.00mm TIR
—	BOX/PAD FACE RUNOUT WITH RESPECT TO SHAFT AXIS (PER 1mm OF SHAFT DIAMETER)	0.00mm TIR
—	BOX/PAD BORE CONCENTRICITY WITH RESPECT TO SHAFT AXIS (PER 1mm OF SHAFT DIAMETER)	0.00mm TIR
—	SHAFT AXIAL MOVEMENT (END PLAY)	0.15mm TIR
—	SHAFT/SLEEVE SURFACE ROUGHNESS	0.2µm Ra
—	BOX/PAD FACE SURFACE ROUGHNESS	1.6µm Ra
—	BOX/PAD BORE SURFACE ROUGHNESS	3.2µm Ra

**GENERAL NOTES**

- ALL DIMENSIONS ARE IN mm UNLESS OTHERWISE SPECIFIED.
- DO NOT SCALE THIS DRAWING. PLEASE ASK IF IN DOUBT.
- RECOMMENDED SPARES ARE MENTIONED IN BILL OF MATERIAL.
- PARTS NOT NUMBERED ARE IN CLIENT'S SCOPE.

**MECHANICAL SEAL DETAILS**

SEAL SERIES	18 SEAL SIZE	38 SEAL SIZE
82	3.875"	

**ORDER DETAILS**

DRG. NO.	DEL. L/P/PS/21-22/50	DRG. DATE	10-12-2021
P.O. NO.	002933	P.O. DATE:	30-12-2021
DRG. NO.		DRG. DATE:	
DEL. NO.	DEL. NO./2122/297	DRG. DATE:	31-12-2021

**LEAK-PROOF ENGINEERING (I) PVT. LTD.**

MUMBAI, INDIA

WWW.LEAKPROOFSEALS.COM | INFO@LEAKPROOFSEALS.COM

DRWN:	FFJ	SIZE:	DWG. NO.:	REV:	ISSUE:	FIGET RANGE:	
CHKD:	JSS	A3	L03333A	0	P0	PRODUCTION	
APVD:	JSS	DATE:	13-12-2021	SCALE:	N/S	WGT:	KG
						SHEET:	1 OF 1

3/4

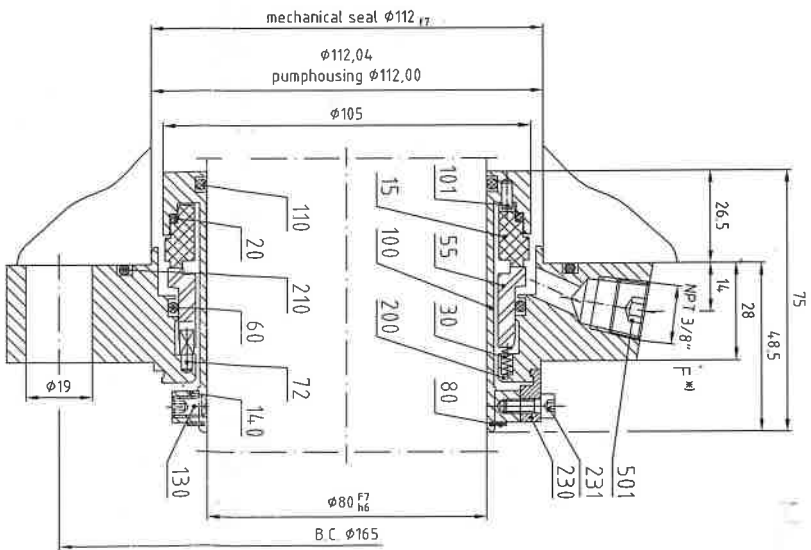
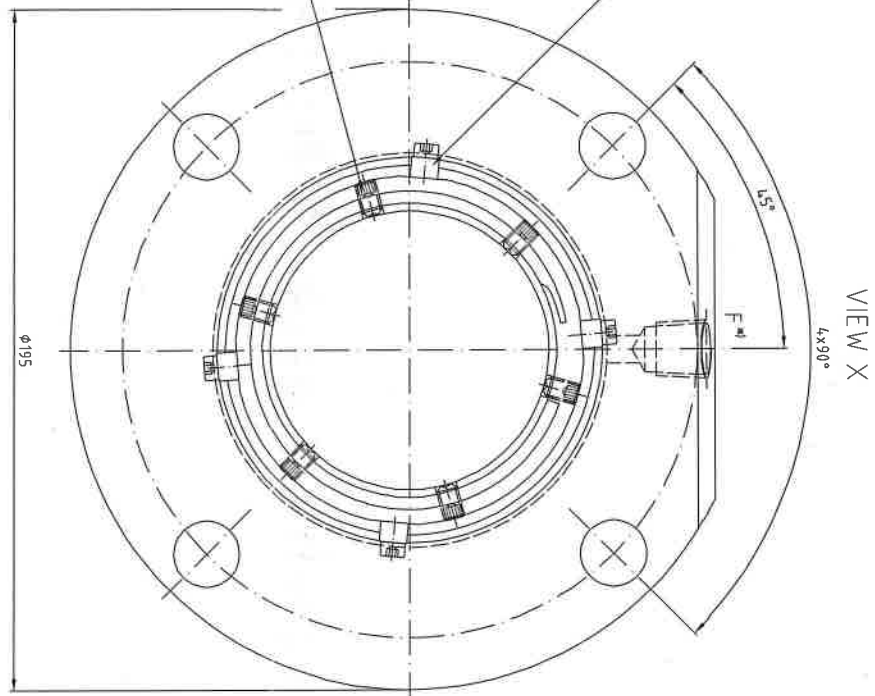

CUSTOMER	LAET MHP'S BOILER PRIVATE LTD., FOR 2x660MW BUXOR THERMAL POWER
DEM	CL-02E CPLE
PUMP MODEL / TYPE	UNICLIDE (9B1)
ITEM NO.	CP1
Suction Pressure (Rated)	0.98 kg/cm2.a
Discharge Pressure (Max)	2.904 kg/cm2.a
CAPACITY m3/hr	450
VISCOSITY (Cp)	-
DESIGN TEMP (°C)	120
SP.GR	0.982
RPM	735
MAMP (kg/cm2 o)	4.4
SERVICE	CONDENSATE TRANSFER PUMP

Part	Qty	Description	Material
501	1	plug	316
231	4	cylinder screw	316
230	4	assembly fixture	4.31
210	1	secondary seal	EPDM
200	1	gland plate	316Ti
140	1	set ring	316Ti
130	5	set screw	316
110	1	secondary seal	EPDM
101	2	pin	316Ti
100	1	shaft sleeve	316Ti
80	1	assembly ring	316
72	4	holding pin	316Ti
60	1	secondary seal	EPDM
55	1	stationary seal ring	silicon carbide
30	26	spring	Hastelloy C4
20	1	secondary seal	EPDM
15	1	rotary seal ring	hard carbon

REVISION	ISSUE	PRODUCTION	SCALE	SIZE
1	REVISED	15/09/2010	A3	
2	REVISED	28/09/2010	A3	

CHETRA SEALS PVT.LTD.		MECHANICAL SEAL	
TYPE 2090CS-080		SHEET : 01 OF 01	
DATE	PROJW	CHECK	APPROVED
28/09/2010	15/09/2010	25/09/2010	21/09/2010
3-SE000176	2	A	

**BID DECLARATION FORM**

Date:

To,  
Head (Procurement & Contracts),  
STPL, BTPP, Main office Building,  
Chausa, Buxar-802114, Bihar

**GEM BID Ref.**

**Sub:**

Dear Sir,

**1.0** Having examined the Bidding Documents (GeM Bid, GeM GTC, STC, ATC, Scope of Work, TS, Annexures etc.) including subsequent amendments and clarifications (if any), the receipt of which is hereby acknowledged, we the undersigned, submit our bid for the subject cited work named GeM Bid, in full conformity with the said Bidding Documents.

**2.0 COMPLIANCE TO THE PROVISIONS OF THE BIDDING DOCUMENTS & NO DEVIATION**

2.1. We have read all the provisions of the Bidding Documents and confirm that notwithstanding anything stated elsewhere in our bid to the contrary, the provisions of the Bidding Documents are acceptable to us and we further confirm that we have not taken any deviation to the provisions of the Bidding Documents anywhere in our bid.

Any deviation, variation or additional condition etc. or any mention, contrary to the provisions of Bidding Documents and its subsequent Amendment(s)/ Clarification(s)/ Addenda/Errata (if any) found anywhere in our bid proposal, implicit or explicit shall stand unconditionally withdrawn, without any cost implication whatsoever to the Employer, failing which our bid shall be rejected.

2.2. We further declare that additional conditions, variations, deviations to the provisions of bidding documents and its subsequent Amendment(s)/ Clarification(s)/ Addenda/ Errata, if any, found in our proposal, shall not be given effect to.

**3.0 PRICE SCHEDULE:**

~~3.1. In line with the requirements of the Bidding Documents, we are attaching, the "Price Schedule/BOQ/Price Breakup of the tendered item as applicable on the Bid publish date" at the 'Financial Document' of the GeM portal, duly filled in in your format.~~

~~3.2. We are aware that the Price Schedule does not generally give a full description of the material/item to be performed under each item and we shall be deemed to have read the Bidding Documents to ascertain the full scope of supply included in each item while filling in the rates and amount/prices. We agree that the entered rates and amount/prices shall be deemed to include the full scope as aforesaid, including overheads and profit.~~

- ~~3.3. We declare that prices left blank in the Price Schedule will be deemed to have been included in the quoted prices of other items/items. The total for price schedule shall be deemed to be the total price for executing the subject package/contract in complete accordance with the Contract, whether or not each individual item has been priced.~~
- 3.4. We declare that the total price filled online on GeM Portal is inclusive of all taxes, duties, levies, cess etc. and GST and if any discrepancy occurs between the online price filled on GeM Portal and total price in Price break up (Price Schedule/BOQ), total online price filled on GeM Portal shall be considered as correct price.
- 4.0 We hereby agree that we shall furnish all necessary justification to establish the reasonableness of the rates/ prices, if required by you.
- 5.0 We hereby undertake that:
- (a) We have not changed the contents of the bidding documents.
  - (b) Scanned copy of documents uploaded along with the bid is true to the best of our knowledge.
  - (c) We have understood the requirement of Technical Specification, Scope of Work, Terms & condition and these shall be complied completely.
  - (d) We are familiar with all the requirements of the Contract.
  - (e) We have not been influenced by any statement or promise of any person of the Employer but only the Contract Documents.
  - (f) We are financially solvent.
  - (g) We are experienced and competent to perform the Contract to the satisfaction of Employer.
  - (h) We are familiar with all general and special laws, acts, ordinances, rules and regulations of the Municipalities, District, State and Central Government of India that may affect the work, its performance or personnel employed therein. We undertake to abide by all labour welfare legislation.
  - (i) We undertake that the information furnished in the Bid is true and correct in all respects.
  - (j) If our bid is accepted, we shall commence the work/contract immediately upon issuance of the Letter of Award / Purchase Order / GeM Contract / Purchase Order and shall complete the Contract within the time period specified in the Bidding Documents.
- ~~6.0 If our bid is accepted, we undertake to provide, Contract Performance Securities and securities (as applicable/if applicable) in the form of amounts and within the GeM bid validity in accordance with the Bidding Documents.~~
- 7.0 We understand that you are not bound to accept the lowest or any other bid you may receive. Further we understand that Employer reserves the right to reject any or all bids or cancel/withdraw the Invitation for Bids without assigning any reason whatsoever and in such case no bidder/intending bidder shall have any claim arising out of such situation.

Date:

**For and on behalf of the bidder**

.....

**(Signature of authorized representative of the Bidder,  
along with his name, Seal of Company)**

**PPR-111/2026 – Procurement of Mechanical seal from GEM portal.**

**UNDERTAKING**

I / We, M/s ..... (Name of Bidder) hereby certify that I / we would adhere to the fraud prevention and detection policy of SJVN and not indulge myself/ourselves or allow anybody else working in my/our organization to indulge in fraudulent activities and would immediately apprise the SJVN authorities regarding fraud / suspected fraud as soon as it comes to my/our notice.

**(Seal & Signature of Bidder)**

**UNDERTAKING**

**PPR-111/2026 – Procurement of Mechanical seal from GEM portal.**

**(In compliance of Ministry of Finance, Government of India order no F. No. 6/18/2019-PPD dated 23.07.2020)**

I have read the clause regarding restrictions on procurement from a bidder of a country which shares a land border with India. I certify that ..... (name of Bidder) is not from such a country or, if from such a country, has been registered with the Competent Authority. I hereby certify that ..... (name of Bidder) fulfills all requirements in this regard and is eligible to be considered.

**Note: Evidence of valid registration by the Competent Authority shall be attached/uploaded (if applicable)**

**Place:**

**Date:**

**(Signature)**

**FORMAT OF LOCAL CONTENT**

Format for Self-certification regarding Local Content in line with PPP-MII order, 2017 and Revision PPP-M II 2017 date 04/06/2020 & 25/06/2019 if applicable, to be provided on company letterhead by the authorized person.

Bidder's Name and Address (Bidder):

Name:

Address:

To,

Head (Procurement & Contracts),  
STPL, BTPP, Main office Building,  
Chausa, Buxar-802114, Bihar

Date: - \_\_\_\_\_

Dear Sir,

I \_\_\_\_\_ S/o,D/o,W/o \_\_\_\_\_  
\_\_\_\_\_ Resident  
of \_\_\_\_\_ here by solemnly affirm  
and declare as under:-

That I will agree to abide by the terms and conditions of the Public Procurement (Preference to Make in India) Order, 2017 (hereinafter PPP-M II order) of Government of India issued vide Notification No: P- 45021/2/2017-BE-II dated 15/06/2017, its revision dated 16.09.2020 & MOP orders dated 20/12/2018, 28/07/2020 & 19/07/2024, as amended from time to time and any subsequent modifications/ Amendments, if any the information furnished hereinafter is correct to the best of my knowledge and belief and I undertake to produce relevant records before the procuring entity/ SJVN Thermal Pvt. Limited or any other Government authority for the purpose of assessing the local content of goods/services/works supplied by me for  
.....  
..... (Enter the name of the Tender).

That the local content for all inputs which constitute the said goods/ services/works has been verified by me and I am responsible for the correctness of the claims made therein.  
That the goods/ services/works supplied by me for .....  
..... (Enter the name of the Tender) meet the 'Minimum Local Content' as defined in Order 16.09.2020 and MOP orders dated 20.12.2018, 28.07.2020 & 19.07.2024, as amended from time to time and value of local content (in.....%).

That the value addition for the purpose of meeting the 'Local Content' has been made at  
.....  
.....  
..... {Enter the details of the location(s) at which value addition is made}. That in the event of the local content of the goods/ services/works mentioned herein is found to be incorrect and not meeting the prescribed Local Content criteria, based on the

assessment of procuring agency (ies)/ SJVN Thermal Pvt. Limited /Government Authorities for the purpose of assessing the local content, action shall be taken against me in line with the Revision PPP-MII order dated 04/06/2020 and Order P-45021/2/2017PP(BE-II) dated 19th July 2024 and provisions of the Bidding Documents.

I agree to maintain the following information in the Company's record and shall make this available for verification to any statutory authority. **Further, Self-declarations/ auditor's/ account's certificates submitted by the manufacturer/ supplier may be verified randomly by the committee constituted as per MOP Order 28-07-2020 & subsequent modification/Amendments if any. In case of false documents/misrepresentation of the facts requisite action against such manufacturer/supplier will be taken based on the recommendation of the Committee."**

- i Name and details of the Local Supplier  
(Registered Office, Manufacturing unit location, nature of legal entity)
- ii. Date on which this certificate is issued
- ii. Goods/services/works for which the certificate is produced

For and on behalf of

.....  
.....

(Name of firm/entity).  
Authorized signatory

Name,

Designation

Contact No.

Date:

**Form of Bank Guarantee for Earnest Money Deposit**  
(To be executed on Non-Judicial Stamp Paper of Appropriate value)

**Name of Contract: PPR-111/2026 – Procurement of Mechanical seal from GEM portal.**

To,  
Head (Procurement & Contracts),  
STPL, BTPP, Main office Building,  
Chausa, Buxar-802114, Bihar

WHEREAS (name of Bidder) (hereinafter called “the Bidder”) has submitted its Bid dated (date of bid) for the performance of the above-named Contract (hereinafter called “the Bid”)

KNOW ALL PERSONS by these present that WE (name of Bank) of (address of bank) (hereinafter called “the Bank”), are bound unto (name of Employer) (hereinafter called “the Employer”) for the sum of: (amount), for which payment well and truly to be made to the said Employer, the Bank binds itself, its successors and assigns by these presents.

THE CONDITIONS of this obligation are as follows:

1. If the Bidder withdraws its Bid during the period of bid validity specified by the Bidder in the Letter of Tender, or adopts corrupt or collusive or coercive or fraudulent practices or default under Integrity Pact.
2. If the Bidder, having been notified of the acceptance of its Bid by the Employer during the period of bid validity.
  - a) fails or refuses to sign the Contract Agreement when required, or
  - b) fails or refuses to submit the performance security in accordance with the Bid Documents.

We undertake to pay to the Employer up to the above amount upon receipt of its first written demand, without the Employer having to substantiate its demand, provided that in its demand the Employer will mention that the amount claimed by it is due, owing to the occurrence of one or both of the two above-named CONDITIONS, and specifying the occurred condition or conditions. For and on behalf of the Bank

---

in the capacity of

---

Common Seal of the Bank

## ***INSTRUCTIONS FOR EXECUTION OF BANK GUARANTEE FOR BID SECURITY***

1. Bank Guarantee for Earnest Money Deposit should be executed on non-judicial Stamp papers of requisite value in accordance with the stamp Act if applicable to that particular state of Indian Union country of executing Bank, where executed. In case the same is issued by a first-class International bank, the law prevalent in the country of execution shall prevail for the purpose of Stamp Duty on the Bank Guarantee. However, in such a case, the Bank Guarantee for Earnest Money Deposit shall be got confirmed by the Bidder through any Indian Scheduled/Nationalized Bank.
2. The executing officers of the Bank Guarantee for Earnest Money/Bid Security shall clearly indicate in (block letters) his name, designation, Power of Attorney No. / Signing Power No. as well as telephone/ fax numbers with full correspondence address of the issuing Guarantee etc.
3. Each page of the Bank guarantee for Earnest Money Deposit shall be duly signed/initialed by the executing officers and the last page shall be signed in full, indicating the particulars as aforesaid (sub-para 2) under the seal of the Bank.
4. Stamp paper shall be purchased in the name of Bank issuing the Bank Guarantee, after the date 'Notice Inviting Tender', not more than six (6) months prior to execution/ issuance of the Bank Guarantee. The name of the purchaser should appear at the back side of stamp paper in the Vendors Stamp. The issuing Bank shall be requested independently for verification/confirmation of the Bank Guarantee issued, non confirmation of which may lead to rejection of 'Bid Security'.
5. Irrevocable, valid and fully enforceable Bank Guarantee in favor of the employer (Name of Employer) issued by any scheduled bank approved by the Reserve bank of India which is acceptable to the Employer. The Bank Guarantee issued by a Foreign Bank shall be routed through the corresponding branch of such scheduled foreign banks in India or any scheduled Bank, acceptable to the employer.
6. Bank Guarantee for Bid security in original shall be submitted along with the Bid. However, the issuing Bank shall submit an unstamped duplicate copy of Bank Guarantee directly by registered post (A.D.) to the Employer (authority inviting tenders) with a forwarding letter.
7. **While preparing the BG in favour of SJVN Thermal Private Limited or extensions thereof as the case may be, bidder may ensure to mention STPL's Bank details in order to BG verification through SFMS facility.**

**CHECK LIST OF DOCUMENTS ENCLOSED WITH TENDER**

Bidder shall upload following documents on GeM Portal as mentioned in the table below:

<b>Sr. No.</b>	<b>Document</b>	<b>Declaration</b>
<b>A. TECHNICAL BID</b>		
<b>1</b>	Signed Bid document with all Annexures & TS/Scope of Work/ATC	Yes / No
<b>2</b>	Bid Declaration Form at <b>Annexure-I</b>	Yes / No
<b>3</b>	Undertaking for Corrupt or Fraudulent Practices at <b>Annexure-II</b>	Yes / No
<b>4</b>	Undertaking for Certification for Procurement of Restriction on Border Sharing Country at <b>Annexure-III</b>	Yes / No
<b>5</b>	Undertaking for Local Content in line with PPP-MII Order at <b>Annexure-IV</b>	Yes / No
<b>6</b>	Bid Security / EMD as per the proforma provided in <b>Annexure-V</b> / Documentary evidence against exemption of EMD	Yes / No
<b>7</b>	<del>Bank Guarantee for Performance Security Deposit as per the proforma provided in <b>Annexure-VI</b></del>	
<b>8</b>	<del>Duly Signed Pre-Contract Integrity Pact as per format attached at <b>Annexure-VII</b></del>	Yes / No
<b>9</b>	Copy of PAN, GST Registration details & Cancelled Check (For return of EMD)	Yes / No
<b>B. PRICE BID</b>		
<b>1</b>	Uploaded Price Schedule/Bill of Quantities (BOQ) under Financial Document on GeM Portal (enclosed as Price schedule)	Yes / No

एसजेवीएन थर्मल (प्रा.) लिमिटेड

**SJVN Thermal (P) Ltd.**

(एसजेवीएन की पूर्ण स्वामित्व वाली अधीनस्थ कंपनी)

(A wholly owned subsidiary of SJVN)

**1320 मेगावाट बक्सर ताप विद्युत परियोजना**

**1320 MW Buxar Thermal Power Project**

CIN: U31908BR2007PTC017646



GSTIN- 10AAFCM1296A1Z4

Email-[pcdbtpp@sjvn.nic.in](mailto:pcdbtpp@sjvn.nic.in)

Website- [www.sjvn.nic.in](http://www.sjvn.nic.in)

**PROCUREMENT & CONTRACTS DEPARTMENT**

☎: 06183-295154

Ref. No.: STPL/08/05/02/PPR-111/2026-214

Dated:-15.06.2026

**Clarification-I**

GeM Bid No. GEM/2026/B/7584307 dated 26.05.2026 for Procurement of Mechanical Seal.

Following clarification have been made in the GeM bid GEM/2026/B/7584307, for **Schedule-1 (Mechanical Seal for Coal Mill Lube Oil Pump)**

Sl. No.	Clarification sought from prospective bidder.	Reply/Remarks of STPL
1.	Requested him to share the GAD/Mechanical Seal Drawing and Pump Model details to enable submission of a technically suitable offer of Mechanical seal.	The GAD/Mechanical Seal Drawing is not available with us. However, the Pump Data Sheet is attached. Interested bidders are advised to visit the site, inspect the existing seal arrangement, take necessary measurements, and develop the drawing/details of the required Mechanical Seal to ensure compatibility with the existing equipment. The bidder shall be responsible for offering a Mechanical Seal that is exactly suitable and fully interchangeable with the existing installation

Other terms and conditions shall remain unchanged.

**For& on behalf of SJVN Thermal (P) Ltd**

**-SD-**

**(Anil Kumar Chaudhary)**

**DGM (Contracts)**

Enclosures: - Pump Data Sheet.

Doc No	TU_24960890_Buxar	Rev 04	Date	22-12-2020				
		PUMP DATASHEET		TUSHACO®				
<b>CUSTOMER</b>	Elecon Hydraulics Pvt Ltd							
<b>PROJECT</b>	SVJNL Buxar							
<b>ITEM</b>	Lube Oil Pump	<b>ENQ No</b>	20001					
<b>GENERAL DATA</b>								
Pump Type	Rotary Positive Displacement Pump, Three Screw		Tag No.					
Manufacturer/Supplier	Allweiler India Pvt Ltd							
Pump Model	T3SI 70/46							
Duty	Lubrication							
Mounting	Flange Mounted							
Inlet Size	NB 100 NP 16 DIN FF		<b>ORIENTATION</b>	LHS -From DE				
Outlet Size	NB 100 NP 16 DIN FF			RHS- From DE				
<b>PERFORMANCE</b>								
LIQUID	ISO VG 320			Sp. Gr.	0.85			
Temperature Range - °C	Min-1	23	Min-2	30	Norm-1	40	Norm -2	65
Viscosity Range - cSt	Max -1	1169	Max - 2	658.4	Norm -1	320	Norm -2	78.1
Pump Speed - RPM	1450				Flow Required	360	LPM	
Discharge Pressure - bar	7.00				Suction Pressure -Atmospheric			
Differential Pressure - bar	7.00							
Displacement - cc/rev	307.4							
Flow Offered at Diff. Pressure - LPM		429		426		420		406
Power Consumed at Diff. Press - kW		9.5		9.0		8.1		6.6
Relief Valve Set Pressure- bar	8.00							
Power Consumed at RV Set Pr.- kW		10.3		9.7		8.8		7.4
Relief Valve Accumulation Pr. - bar	9.00							
Power Consumed at RV Acc. Pr. - kW		11		10.4		9.6		8.1
Hydraulic Power at Diff Pressure	5.10							
Drive	Direct							
Recommended Drive Power	15 kW, 4 pole							
Efficiency %age	at 1169 cSt		at 658.4 cSt		at 320 cSt		at 78.1 cSt	
Volumetric Efficiency -%	96.3		95.6		94.2		91.1	
Mechanical Efficiency - %	53.7		56.7		63.0		77.3	
Overall Efficiency - %	51.7		54.2		59.3		70.4	
Pump NPSHr m	10.0		7.0		4.7		3.5	
Noise Level & Vibration at Diff. Pr.	Noise Level:85dbA at 1MTR Radius			Vibration Velocity :3.5mm/Sec				
Bare Pump	Weight : ~ 65 kg			Rotation :CW				
Casing MAWP	9.90 bar							
Hydrostatic Test Pressure	Casing : 16.5 bar			Pump Design Pressure - 10.9 bar				
<b>MATERIAL OF CONSTRUCTION</b>								
Casing/Cover/Stuffing Box	Casing :Cast Iron , Cover/Stuffing Box :Cast Iron IS:210 FG260							
Screw/Shaft	Alloy Steel - 16MnCr5							
Liner	Integrated		Balance Bush	Al Alloy				
Seal	Type : Single Elastomeric Bellow		Make	JC/EBIL/Roplan/Equivalent				
Bearing	Type Groove Ball Brg.		Size/Designation : 6309					
Motor Mounting Frame/Padestal	Not In scope							
Coupling	Type	Not In scope		Size	MOC			
Relief Valve	Provision : Built On		Make	Allweiler India		Type		
Performance Guarantee	VDMA 24284 GR II CLASS II							
Remark	Efficiencies Are Indicative Only And Subject To Change & Acceptance As Per Permitted Tolerances On Flow & Power As Per Test Code.							
	Excess Flow Permitted (Beyond Permitted Tolerances as per Test Code)							